



**Techni**  
ENGINEERING SOLUTIONS

**IVECO**

**EUROCARGO EURO VI 6.7 LITRE**

**TECTOR 7 - 162/185/206/235 KW**

---

**CODE / CODICE: 0500.7962**

**COMPRESSOR / COMPRESSEUR / KOMPRESSOR  
/ COMPRESSORE / COMPRESOR :**

**SELTEC: TM13/15/16**

**QUE: QP13/15/16**

**SANDEN: SD7H15**

---

**FITTING INSTRUCTIONS**

**EINBAUANLEITUNGEN**

**INSTRUCTIONS POUR LE MONTAGE**

**ISTRUZIONI DI MONTAGGIO**

**INSTRUCCIONES DE MONTAJE**

---



**Contents**

<b>ENGLISH</b> .....	3
Parts View.....	3
Parts List .....	3
Compressor Configurations .....	4
Standard Fastener Torque Values .....	4
Kit Details .....	5
Vehicle Details .....	5
Forward .....	5
Pre-Installation .....	6
Installation .....	6
Mount Bracket Installation .....	6
Compressor Installation.....	7
Drive Belt Installation .....	7

PARTS VIEW / VUE ÉCLATÉE / TEILEANSICHT / VISTA PARTA / IMÁGENES DE LAS PIEZAS

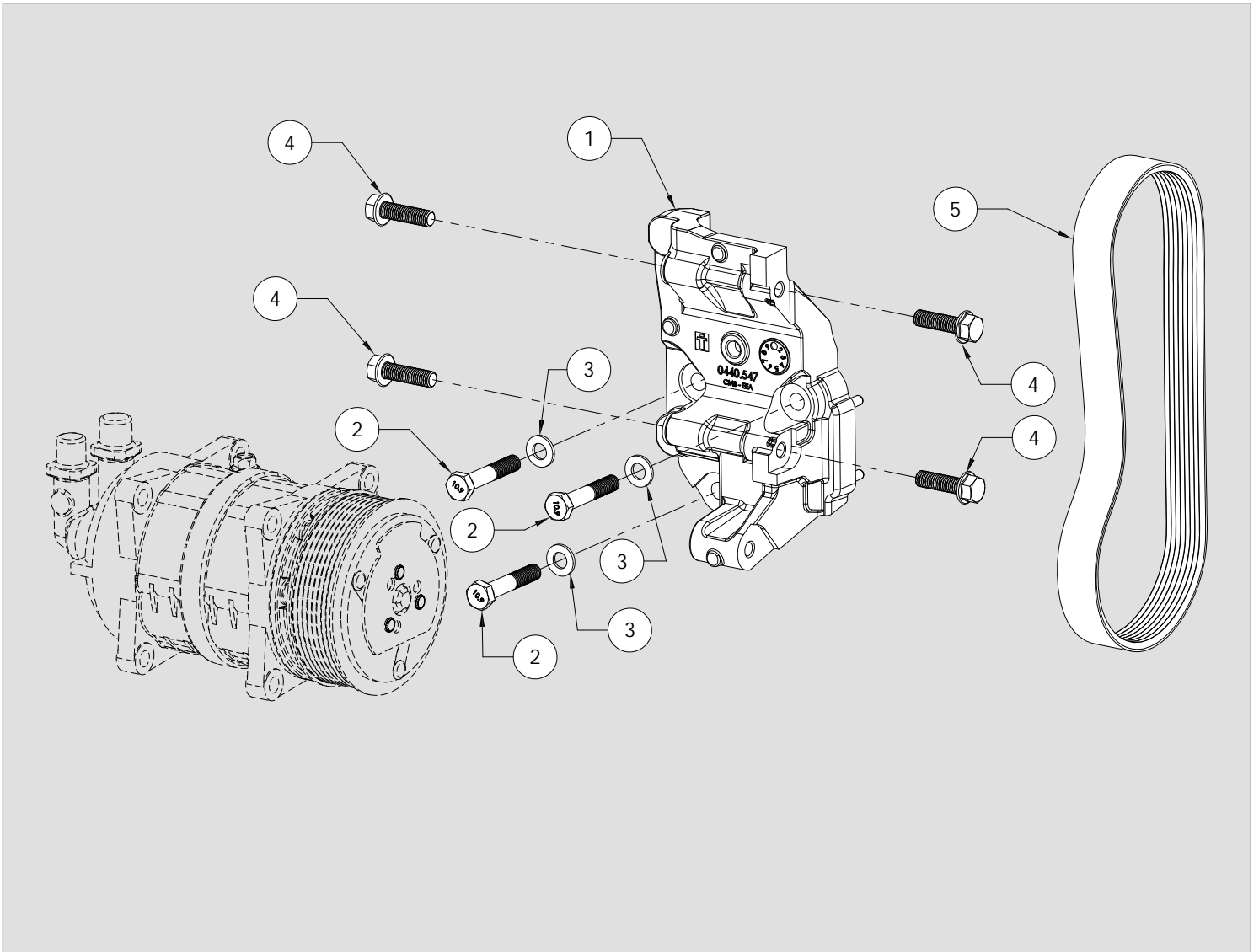

**PARTS LIST / NOMENCLATURE / TEILELISTE / ELENCO DELLE PARTI / LISTA DE PIEZAS**

ITEM	CODE / CODICE / KODE / CODIGO	DESCRIPTION / DESCRIZIONE / BESCHREIBUNG / DESCRIPCION	QTY.	COMMENTS
1	0440.5471	Compressor Mount Bracket	1	
2	2705.5331	Hexagon Head Bolt - M10 x 55 : 10.9	3	
3	2809.0011	Washer M10 Flat DIN 125 - A 10.5	3	
4	2705.0241	Hexagon flange bolt Durlok - M10 x 35 : 1.50 - 12.9	4	
5	0820.1441	Belt - Poly Groove 8PK 1725	1	

**COMPATIBLE COMPRESSORS / COMPRESSEURS RECOMMANDÉS / EMPFOHLENE KOMPRESSOREN  
RACCOMANDATO COMPRESSORI / RECOMENDADAS COMPRESORES**

SELTEC	TM-13	TM-15	TM-16
Comp No	0381.0972	0381.0982	0381.0992
Valeo No.	-	-	-
Mounting	EAR	EAR	EAR
Rotor	8PV	8PV	8PV
GL	46.55	46.55	46.55 mm
Armature	SL	SL	SL
Diameter	119	119	119
Voltage	24	24	24
Orientation	V	V	V
Fitting	3/4 x 7/8	3/4 x 7/8	3/4 x 7/8
Manifold	Bolt	Bolt	Bolt

QUE	QP-13	QP-15	QP-16
Comp No	0391.0972	0391.0982	0391.0992
Que No.	-	-	-
Mounting	EAR	EAR	EAR
Rotor	8PV	8PV	8PV
GL	46.55	46.55	46.55
Armature	SL	SL	SL
Diameter	119	119	119
Voltage	24	24	24
Orientation	V	V	V
Fitting	3/4 x 7/8	3/4 x 7/8	3/4 x 7/8
Manifold	Bolt	Bolt	Bolt

SANDEN	-	-	-
Comp No	-	-	-
Sanden No.	-	-	-
Mounting	-	-	-
Rotor	-	-	-
GL	-	-	-
Armature	-	-	-
Diameter	-	-	-
Voltage	-	-	-
Orientation	-	-	-
Fitting	-	-	-

NOTES

**STANDARD FASTENER TORQUE VALUES**

In the absence of specific torque values detailed in this fitting instruction manual, the following chart can be used as a guide to the maximum safe torque for specific size and grade of fastener.

**COUPLES DE SERRAGE DES FIXATIONS STANDARDS**

Si des chiffres de serrage au couple particuliers ne sont pas indiqués dans cette notice de montage, se référer au tableau suivant qui servira de guide pour le couple de sécurité maximum correspondant à une taille et un grade spécifiques de fixation.

**ANZIEHMOMENTE FÜR STANDARDBEFESTIGUNGSMITTEL**





Falls in dieser Einbauanleitung keine speziellen Anziehmomente angegeben sind, kann die folgende Tabelle als Richtlinie für das maximale sichere Anziehmoment für eine spezifische Größe oder Qualität von Befestigungsmitteln dienen.

**VALORI STANDARD DI SERRAGGIO PER DISPOSITIVI DI FISSAGGIO**

In assenza di valori specifici di coppia nel presente manuale di istruzioni, si può utilizzare la seguente tabella come guida per conoscere la coppia massima sicura in base a dimensioni e grado del dispositivo di fissaggio.

**VALORES ESTÁNDAR DE LOS PARES DE APRIETE Y FIJACIÓN**

En ausencia de valores para los pares de apriete específicos detallados en este manual de instrucciones de montaje, se puede utilizar la siguiente tabla como guía para consultar el máximo par de torsión seguro para un tamaño concreto y su grado de fijación.

STRENGTH								
	Max Torque		Max Torque		Max Torque		Max Torque	
Dia / Pitch	lb.ft	Nm	lb.ft	Nm	lb.ft	Nm	lb.ft	Nm
M5 x 0.80	2	3	4.5	6	6.5	9	7.5	10
M6 x 1.00	4	5.5	7.5	10	11	15	13	18
M8 x 1.25	10	13	18	25	26	35	33	45
M10 x 1.25	20	27	39	53	57	78	66	90
M10 x 1.50	18	25	37	50	55	73	63	86
M12 x 1.75	33	45	63	85	97	130	111	150
M14 x 2.00	55	75	103	140	151	205	177	240
M16 x 2.00	85	115	159	215	232	315	273	370

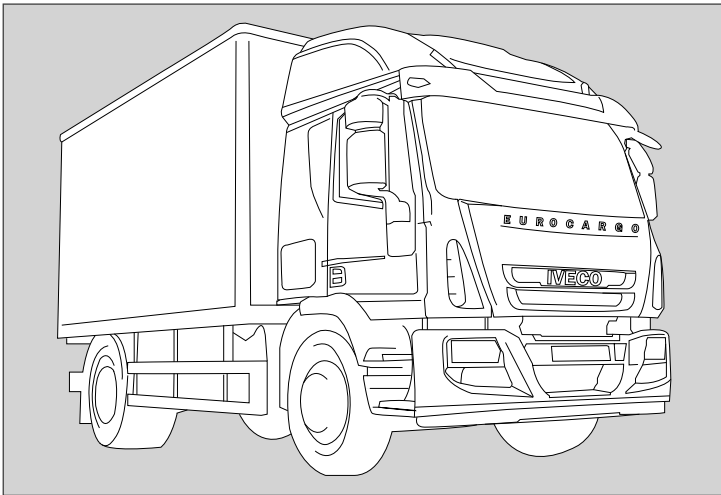

## VEHICLE DETAILS

Manufacturer	Iveco
Model	Eurocargo Euro VI
Engine CC	6.7 Litre
Engine Details	Tector 7 - 162/185/206/235 kW
Year	2014>
Chassis Nos.	N/A
LHD	YES
RHD	YES
PAS	YES
A/C	NO
Voltage	24v

## KIT DETAILS

Kit Part Number	0500.7962
Description	Speed Reduction Kit
Compressor RPM	3613 @ Max engine power output
Fitting Time	45 Minutes
Suction Fitting	90°
Discharge Fitting	90°
Belt Type	8PK 1725
Belt Part Number	0820.1441

## FOREWORD

The purpose of this manual is to facilitate the installation of a direct drive compressor. The information given is merely instructive, should any complications arise contact the Technical department. The manufacturer's warranty does not cover any problems caused by defective installation or alterations made unless authorised. The manufacturer shall not be responsible for any injury, damage or loss caused directly or indirectly as a result of using this manual or the information contained within it.

### 1 SAFETY MEASURES:

**Before fitting the Compressor adapter drive kit, ensure the following for damage:**

- a Inner and outer trim and body work
- b Engine idle pace
- c Check all the vehicle functions

#### Check list:

- a Ensure that the right kit has been selected
- b Before installing, check that all the correct pieces are present; also ensure that there are no missing or broken pieces
- c When fitting, make sure the vehicle is properly protected against damage.

#### Installation apparatus

- a Calibrated torque wrench
- b Hand service tools
- c Protective covers and shields

### 2 PRECAUTIONS

- a Detach the battery negative lead.
- b Torque all bolts where stated using a calibrated torque wrench.
- c Take extreme care with moving parts.
- d Remove the vehicle's ignition key and keep it with you.
- e Wear safeguards and make sure that liquid refrigerant never touches your skin

**Caution:** Measures must be followed accurately to steer clear of the possibility of damage to individuals

**Warning:** This calls awareness to actions which must be pursued to avoid damage to the components.

**NB:** This calls awareness to make the job easier or gives useful information.

**PRE-INSTALLATION**

**N.B** Prior to commencing work, please examine the instructions with care. The alphabetical symbols on the diagram relate to written instructions, numerical symbols relate to the parts listing.

**INSTALLATION**

1. Remove and discard the original drive belt (A) - Fig 1

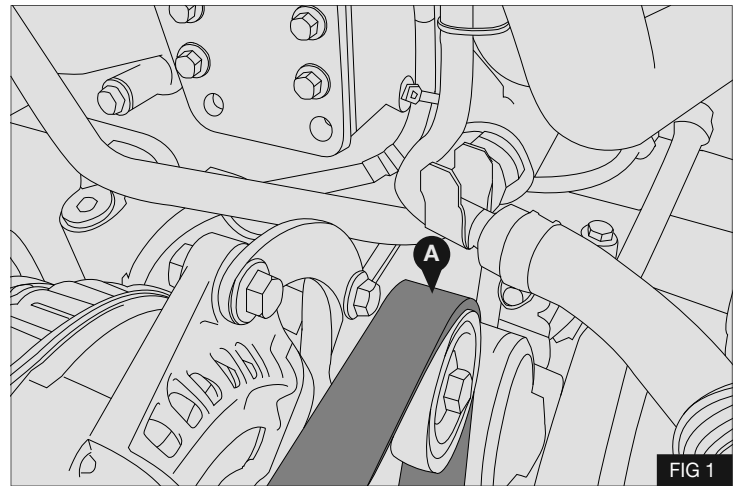

2. Remove and retain idle pulley (B) - Fig 2
3. Remove and discard the alternator plate (C) and securing bolts (C) - Fig 2

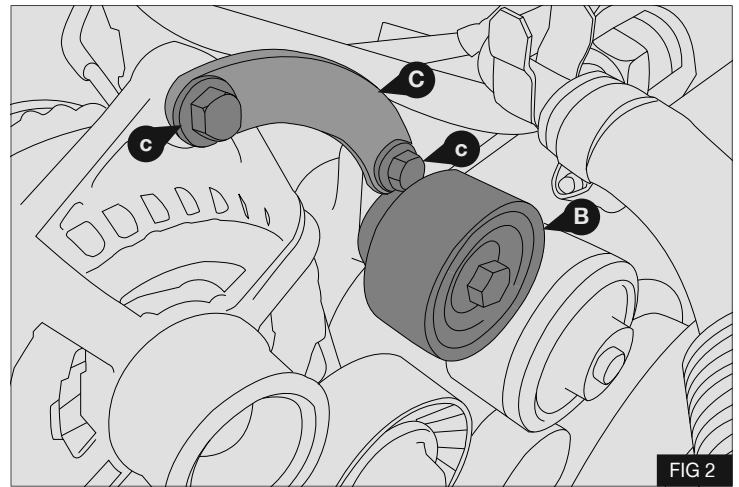
**MOUNT BRACKET INSTALLATION**

1. Insert the supplied M10 bolts (2) into the holes (D) to check that the engine lifting plate (E) is correctly aligned. If the bolts go straight into the thread no further action is required. If the bolts catch on plate (E) or do not screw in at all then plate (E) must be loosened and correctly aligned - Fig 3
2. Remove bolts (2)

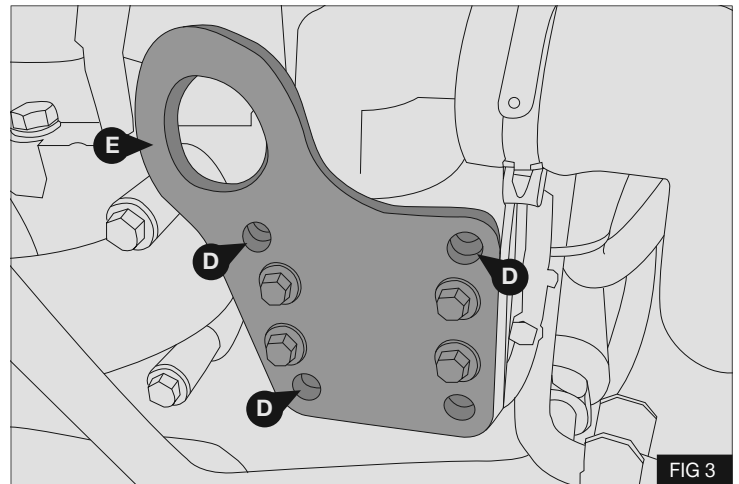

3. Install the mount bracket (1) to the engine using the supplied M10 x 55 bolts (2) with washers (3) - Fig 4

**Note:** Do not fully tighten bolts (2) at this stage.

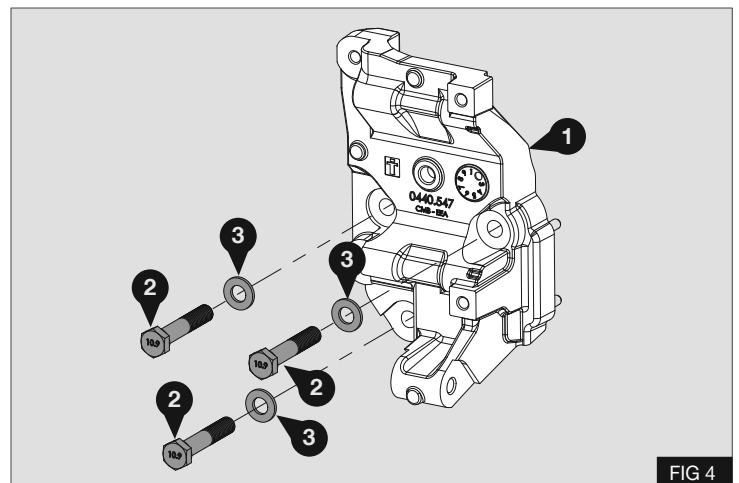



- Align the 6mm dowel pins (F) located in the mount bracket (1) so that they both touch the front face (G) of the engine - Fig 5
- Torque the 3x M10x55 bolts (2) to 48Nm / 35.4lb-ft using a calibrated torque wrench - Fig 5

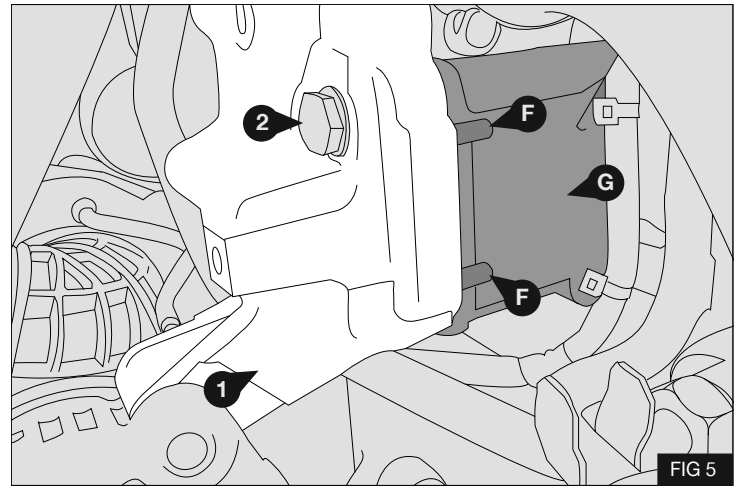

Refit the previously removed idle pulley (B) to the position shown opposite. The idle pulley (B) should now secure the alternator to the mount bracket (1) - Fig 6

Torque the idle pulley bolt (B) to 45Nm / 33.2 lb-ft

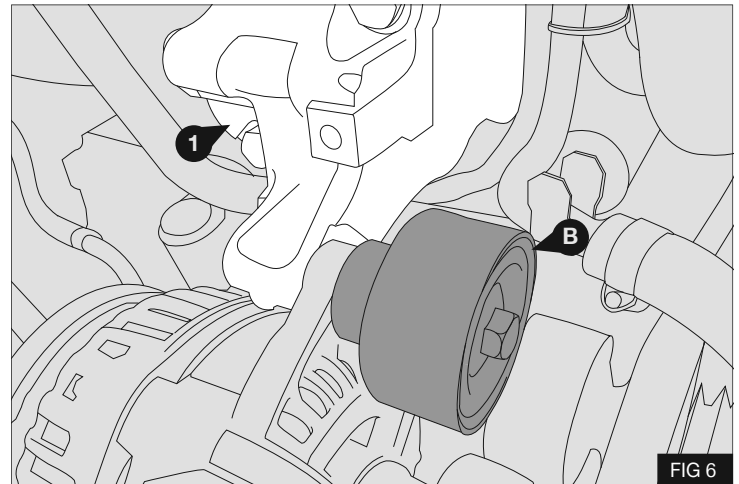

### COMPRESSOR INSTALLATION

- Install the compressor to the mount bracket (1) and secure using 4 x M10 x 35 bolts (4) Fig 7

Torque bolts (4) to 58Nm / 42.8 lb.ft

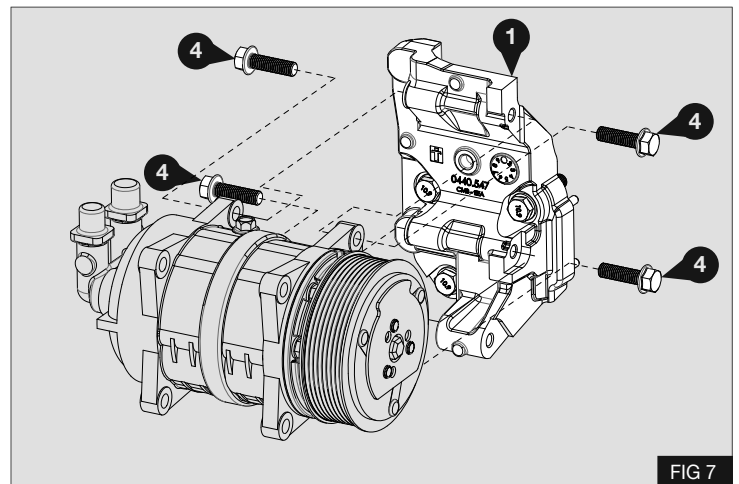

### DRIVE BELT INSTALLATION

- Feed the supplied drive belt (5) over the viscous fan and install the drive belt to the pulleys as shown opposite - Fig 8

A - Crankshaft Pulley  
 B - Idle Pulley  
 C - Tensioner  
 D - Alternator  
 E - Compressor  
 F - Water Pump

- Place the belt (5) over the pulley (F) last.
- Run the engine with compressor engaged for five minutes. Check all components.

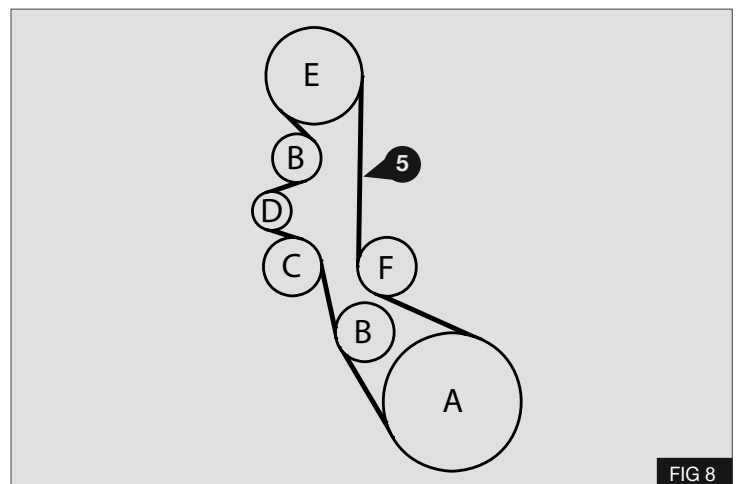





(EN)

Techni focuses on constant upgrading of its products. The Manufacturer reserves the right to modify the models and components described in the present publication at any time for technical or commercial reasons and without prior notice. For further information, contact Techni technical services.

(DE)

Techni ist stets bestrebt die eigenen Produkte zu verbessern. Die Herstellerfirma behält sich das Recht vor, aus technischen oder Verkaufsgründen, zu jeder Zeit und ohne vorherige Ankündigung, Abänderungen an den Modellen und den in dieser Veröffentlichung beschriebenen Einbauteile vorzunehmen. Für weitere Informationen bitten wir Sie, sich an unseren Techni Kundendienst zu wenden.

(FR)

Techni vise à une amélioration constante des ces produits. La maison se réserve le droit d'apporter, à tout moment et sans préavis, des modifications aux modèles et aux composants décrits dans cette publication pour des raisons d'ordre technique ou commerciale. Pour d'ultérieures informations s'adresser au service d'assistance Techni.

(IT)

Techni mira ad un costante miglioramento dei propri prodotti. La Casa si riserva il diritto di apportare in qualunque momento e senza preavviso modifiche ai modelli e ai componenti descritti in questa pubblicazione per ragioni di natura tecnica o commerciale. Per ulteriori informazioni rivolgersi al servizio assistenza Techni.

(ES)

Techni aspira a un constante mejoramiento de su producción. La Fábrica se reserva el derecho de aportar en cualquier momento y sin preaviso modificaciones a los modelos y los componentes descritos en esta publicación por razones técnicas o comerciales. Para ulteriores informaciones dirigirse al servicio asistencia Techni.

VENDITA E SERVIZIO  
VENTE ET SERVICE

SALES AND SERVICE  
VERKAUF UND SERVICE



Sundorne Trade Park, Henley Way,  
Shrewsbury, United Kingdom, SY1 4NS  
Telephone (+44) (0) 1743 443176  
Fax (+44) (0) 1743 443113  
Email: [sales@techni.co.uk](mailto:sales@techni.co.uk)